

Planning Guide

Overview

Choosing a
Location

Site Preparation

Assembly and
Equipment
Installation

Water Quality
System

Operation

OVERVIEW

Our Fastlane Pool provides an ideal way to swim at home without the expense of a traditional pool. It sets up in less than an hour and can easily be moved indoors in the winter. The Fastlane Pool System includes a freestanding pool utilizing a durable powder coated steel structure and a fiber-reinforced membrane. Also included in the system is a variable-speed counter-current swim unit, a water quality system to filter and sanitize the water, and a ladder.

CHOOSING A LOCATION FOR YOUR FASTLANE POOL™

Our Fastlane Pool fits just about anywhere. Garages, patios, backyards, gardens, even the basement can accommodate a Fastlane Pool. The footprint of our standard unit is just 10' by 14' 6". We also offer a larger pool that is 4' longer than standard.

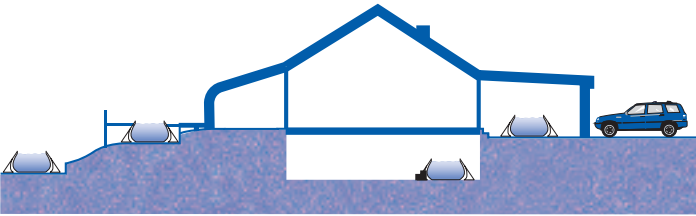

The 48" tall pool when full is 44" deep so the floor loading can be as much as 250 pounds per square foot. Any near level surface on grade can typically accommodate the pool. Non-level surfaces should be avoided.

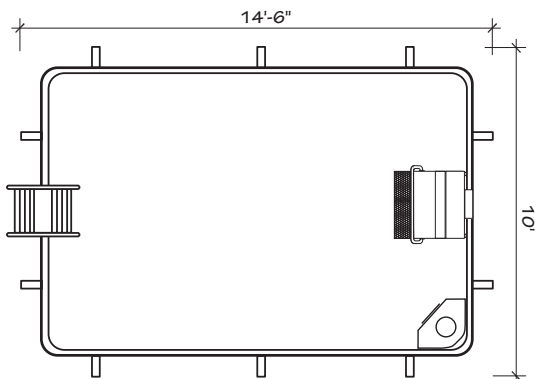
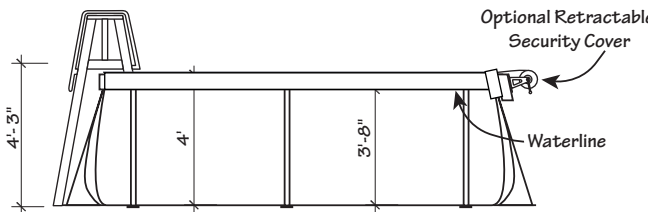

SITE PREPARATION

A Fastlane Pool can be erected on grass, brick, cement, even gravel. The 60 mil. fiber reinforced membrane is amazingly tough but care should still be taken to avoid sharp objects under the pool. Be sure to level the area where the pool is to be installed. Variations of an inch or two can be accommodated by shimming the legs of the pool before filling.

The circulating pump, optional heater and the 5 HP Hydraulic Power Unit must be located at least 10' from the pool and needs a 30 amp, 220 volt, 4 wire GFCI circuit. Installing this equipment on a solid level surface is best. The Fastlane swim current generator which hangs on the front wall of the Fastlane Pool comes with 25' of hydraulic hose to connect to this remote equipment. We also supply a 50' roll of 1-1/2" flexible pipe to connect the circulating pump and optional heater to the connections at the front of the pool. Due consideration should be made regarding the location of this equipment, the source of electric power, and the path for pipe between equipment and pool. If hose runs in excess of 25' are necessary we can supply additional hydraulic hose. For indoor locations adequate drainage should be provided adjacent to the pool and equipment.

ASSEMBLY AND EQUIPMENT INSTALLATION

The pool can be assembled within one hour without any tools.

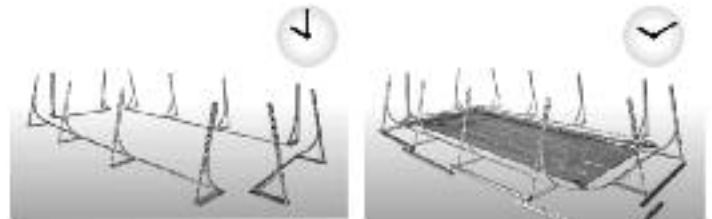

Assembly of the legs and the lower parts of the metal frame

Location of the liner



Assembly of the upper parts of the metal frame

Now the pool is ready!



Water Quality System

- 1) Optional Heater/Controller with keypad
- 2) 5 HP electric motor
- 3) Circulating pump (120 watts, continuous duty)
- 4) Water Line from Fastlane Pool skimmer/filter
- 5) Water Line to Fastlane Pool

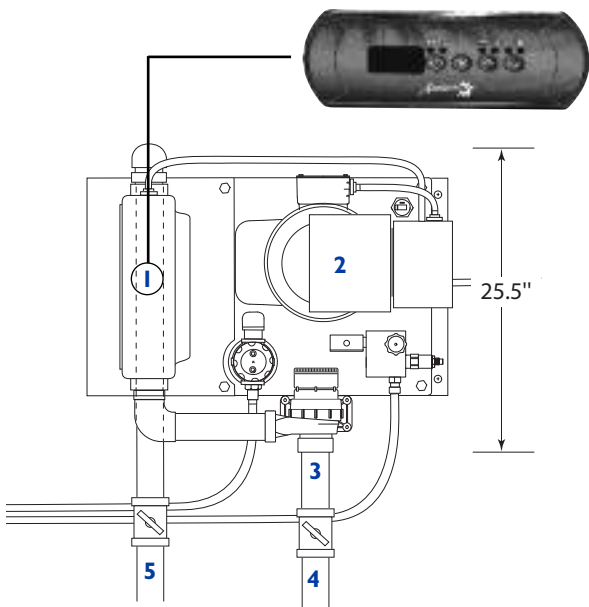

Hydraulic Power Unit (Fastlane Swim System)

- 1) 3/8" hydraulic hose from In-Pool Fastlane (25')
- 2) 5 HP electric motor
- 3) 5 gallon vegetable oil reservoir
- 4) Radio remote control and equipment power center
- 5) 3/8" hydraulic hose to In-Pool Fastlane (25')
- 6) Power Supply

Power Requirements: one 30 amp, 220 volt, 4 wire GFCI circuit

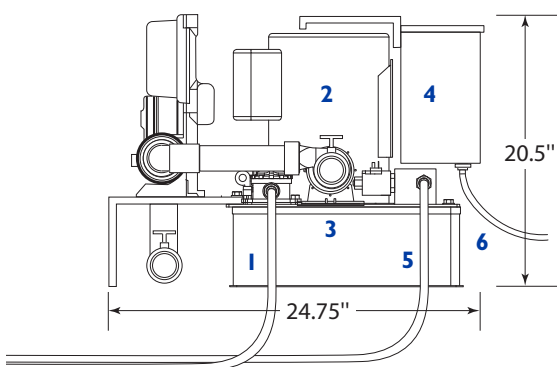

SPECIFICATIONS:

- 10' x 14' 6" footprint
- water capacity: 3,000 gallons
- water depth: 44"
- wall height: 48"
- powder-coated steel framework
- ladder

- rugged 60 mil reinforced membrane
- solar blanket
- circulating pump
- cartridge type skimmer/filter
- 5 hp Fastlane swim current generator

OPTIONS:

- high performance 6 hp Fastlane
- 7" high-visibility LED swim pace display
- underwater stainless steel floor mirror
- electric, gas or propane heater
- retractable security cover
- wood steps

OPERATION OF THE EQUIPMENT

Water Quality System

Water is recirculated from the pool through a skimmer/filter to the equipment shown at left. We provide a Nature 2 copper/silver cartridge that is placed in the skimmer/filter to reduce your use of chlorine. The water then passes through a ball valve and into a high efficiency pump that circulates water continuously. From there the water enters the optional heater which heats the water to a user selected temperature before returning to the pool.

Swim Current System

The swim current in a Fastlane Pool uses the same high volume, low turbulence system as the original Endless Pool. A 16" diameter hydraulically-powered propeller moves a large volume of water through arrays of turning vanes and conditioning grills. A submerged stainless steel hydraulic motor using high pressure vegetable oil rotates the propeller creating the variable speed swim current. The high pressure oil is pumped by the Power Unit through high pressure hydraulic lines over to the pool, through two thruwall fittings at the waterline and down into the swim current generator housing the hydraulic motor. The swim current is controlled with a three button waterproof remote. An optional 7" digital display shows the speed of the swim current as 100 yard pace.

RETRACTABLE SECURITY COVER

The optional retractable security cover acts as a horizontal fence sealing off access to the pool. When in place the cover controls 90% of the humidity, making it ideal for indoor installations. Outdoors the cover seals out dirt, leaves and debris.

The cover retracts onto a roller at the front of the pool and deploys along low-profile tracks. A lock-down mechanism is available to secure the cover over the pool. The cover system track and end roller mount to the deck or coping provided locally. We can include the hardware to construct a very simple perimeter coping using 5/4" deck boards.

The cover meets stringent ASTM F1346 safety standards and is strong enough to support the weight of an adult. We strongly recommend the security cover for installations that are accessible to children, non-swimmers and pets, or for installations in which humidity, falling leaves, or heat loss are concerns. The cover must be installed at the front of the pool where the swim unit is located.

The Retractable Security Cover requires a minimum 24" space to be installed properly at the front of the pool.

Swim...

Visit the Endless Pool, Inc. factory showroom located just 15 minutes from the Philadelphia airport, 3 miles off I-95 between Route 352 and Route 452 on Dutton Mill Road overlooking Chester Creek. Showroom hours are 8:00 am to 5:00 pm Monday through Friday, and weekends by appointment. Please call 1-800-732-8660 and schedule a test swim.



Endless Pools, Inc.
1601 Dutton Mill Rd
Aston, PA 19014-2831
www.endlesspools.com
swim@endlesspools.com
800.732-8660 US
610.497.8676 Local
610.497.9328 Fax

